

Cleaning and Maintaining Your Windows

Cleaning Window and Door Frames

Vinyl and aluminum windows and doors come closer to being maintenance free than any other exterior building product on the market today. They may become dirty just as does a freshly painted house or a new automobile, or any other product, which is exposed to atmospheric conditions.

However with very little effort, you can keep your windows and doors clean. In most cases, a heavy rain is sufficient to clean these products, or you can wash them down with an ordinary garden hose. Do not wash the windows or doors with a high-pressure spray. The extreme pressure could crack or destroy the caulking around the window or door.

If neither rain nor hosing does a satisfactory job, follow these simple instructions:

Normal Maintenance

Wash using a soft cloth or ordinary long-handled soft bristle brush. For textured surfaces, use only a soft bristle brush to avoid smearing the stain into the grooves of the texture.

To wash an entire house, start at the top and work down to the bottom in order to prevent streaking.

For dirt and stains that are difficult to remove such as top soil, motor oil, lithium grease, crayon, felt-tip pen, caulking, lipstick, grass, bubble gum, mold and mildew, use readily available household cleaners that can be mixed with water, such as Fantastik®, Murphy's Oil Soap®, Windex®, Lysol®, Lestoil®, or a solution of vinegar (30%) and water (70%).

Most cleaners are inefficient in cleaning stains such as pencil, paint, oil, and tar. In these cases you may wish to use a mildly abrasive cleaner, such as Soft Scrub®, Ajax®, Bon Ami®, etc., but please remember, the use of any abrasive material could have a deleterious effect on surface appearance.

For exterior applications, the method above can be followed; however, a garden hose can be used to dislodge any soil and perform the final rinse. Caution should be used, for many operable windows and doors are not designed to withstand direct, full-pressure, full-volume spray from a typical garden hose. Such windows may allow water to penetrate into unwanted locations when subjected to such a spray. When using a garden hose, always apply the water at a low volume, using moderate water pressure, and an indirect spray. Always start with windows on the upper floors and work down. Minimize the amount of water running over the lower portions of the building to avoid other stains or damage.

Label Removal

Only remove temporary labels that do not indicate certification of the products. Temporary labels are generally applied to the glass and obviously impede the view. Permanent labels such as AAMA and WDMA product certification labels are not to be removed. Permanent labels will generally be located in

inconspicuous locations in the jamb track of windows or can only be seen when the window is open.

Caution: Use extreme care when removing labels. Avoid scratching the glass with razor blades or other sharp tools.

Note: Masking tape should not be used on glass surfaces. Masking tape may, when heated by sunlight, bake into the glass and/or window frame, causing damage when removed.

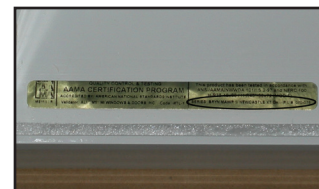

Sash Lubrication

Occasionally the sash operates with difficulty and needs minor lubrication. Tracks should always be lubricated according to the manufacturer's instructions.

Before lubricating movable panel tracks, the installer should verify that the lubricant is compatible with the vinyl, aluminum, or other materials used in the products' assembly. We recommend a spray furniture polish for best results on any plastic parts. Avoid using silicone aerosol sprays because some solvents may dissolve plastic components, and/or prematurely shorten the life of the Insulated Glass.

IMPORTANT: Do Not Paint Vinyl Windows

Special Information On Exterior "Weep Holes"

Some of our window and door products come with built in exterior water drainage systems that we refer to as "weep holes." These "weep holes" appear on the exterior of our window and door products at the sill area. There are two weep holes on each unit, which are designed to have this type of exterior water drainage system. These "weep holes" must remain clear and open to the exterior elements.

IF THESE HOLES ARE BLOCKED, YOU MAY HAVE THE POSSIBILITY FOR WATER INFILTRATION INSIDE YOUR HOME!

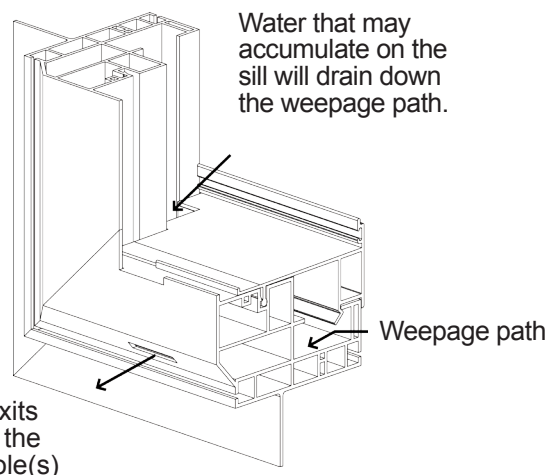

Adjusting Rollers on Sliders

Adjustment of the rollers can usually be accomplished in one of two ways. Some roller housings are not adjustable, but can be raised or lowered by placing or removing spacers under the housing. To remove or add spacers, follow the directions above for sash removal. Then, remove the housing and make the necessary adjustments.

Other rollers can be adjusted by a simple turn of a screw, which raises and lowers the sash. In many cases, the sash does not have to be removed. Always check for an access hole, which allows for adjustment of the rollers prior to removal of the sash. Holes will either be exposed to view or will be covered by a plastic hole plug. Hole plugs can be easily removed by gentle force, using your fingernails or a flat, thin spatula. Once you have gained access to the adjustment screw, simply turn the screw to adjust the sash, either higher or lower.

Cleaning Roller Tracks on Doors and Sliders

The roller track will often collect construction debris, which will result in rough operation of the sash. If the sash does not glide smoothly across the sill, check the sill track for debris. To clean the roller track, simply use a vacuum cleaner to pick up the loose material, then use a cloth or sponge and soap and water to finish the cleaning.

Patio Door Maintenance Locking Mechanism Adjustment

Sliding glass doors are very similar to sliding windows, with the exception of the locking mechanism provided. Locking mechanisms can be adjusted by turning the adjustment screws. To make adjustments to the lock, unlock and open the door until full access to the locking jamb is permitted. Inspect the lock for attachment and adjustment screws. To adjust the amount of throw (reach) the lock cam will have, simply rotate the adjustment screw, then close the door and throw the lock. Check the clearance again by trying to open the door while in the locked position. A limited amount of play should be allowed between the lock and the keeper.

Patio Door Screen Adjustment:

Screens can be designed a number of different ways. Regardless of whether the screen rolls on rollers at the sill or is mounted to a roller housing in the head, minor adjustments can be made. If the screen has rollers at the sill, check the opposing ends of the screen frame for access holes, which will allow for adjustment of the screen. If the screen is mounted with rollers at the head, screen adjustment should be accomplished either from the ends or from the face of the screen. By turning the adjustment screws, the screen will raise and lower at each end to ensure smooth operation.

Cleaners for Stain Removal of Vinyl Window and Door Frames

Gum	Fantastik®, Murphy's Oil Soap®, A solution of 30% vinegar and 70% water, Windex®
Crayon	Lestoil®
DAP® (oil based caulk)	Fantastik®
Felt-tip Pen	Fantastik®, Water based cleaners
Grass	Fantastik®, Lysol®, Murphy's Oil Soap®, Windex®
Lipstick	Fantastik®, Lysol®, Murphy's Oil Soap®
Lithium Grease	Fantastik®, Lysol®, Murphy's Oil Soap®, Windex®
Mold and Mildew	Fantastik®, A solution of 30% vinegar and 70% water, Windex®
Motor Oil	Fantastik®, Lysol®, Murphy's Oil Soap®, Windex®
Oil	Soft Scrub®
Paint	Brillo® Pad
Pencil	Soft Scrub®
Rust	Fantastik®, Murphy's Oil Soap®, Windex®
Tar	Soft Scrub®
Top Soil	Fantastik®, Lestoil®, Murphy's Oil Soap®

Do not use cleaners containing organic solvents or other aggressive ingredients because they could affect the surface appearance. Examples of such cleaners are: chlorine bleach, liquid grease remover, strong soaps, nail polish remover and detergents containing organic solvents. IMPORTANT: DO NOT PAINT VINYL OR ALUMINUM PRODUCTS.

Products are registered trademarks of their respected companies

Customer Care **717-365-2500** – Monday Through Friday 8 am to 5 pm EST



650 West Market Street ■ Gratz, PA 17030 ■ 717-365-3300 ■ www.miwd.com

For additional product information, technical documents, installation instructions and warranty information, please visit: www.miwd.com